

Installation and operating instructions

JUDO PROMI-PLUS

Domestic water station $\frac{3}{4}$ " - $1\frac{1}{4}$ "

Valid for: EU countries and Switzerland

Language: English

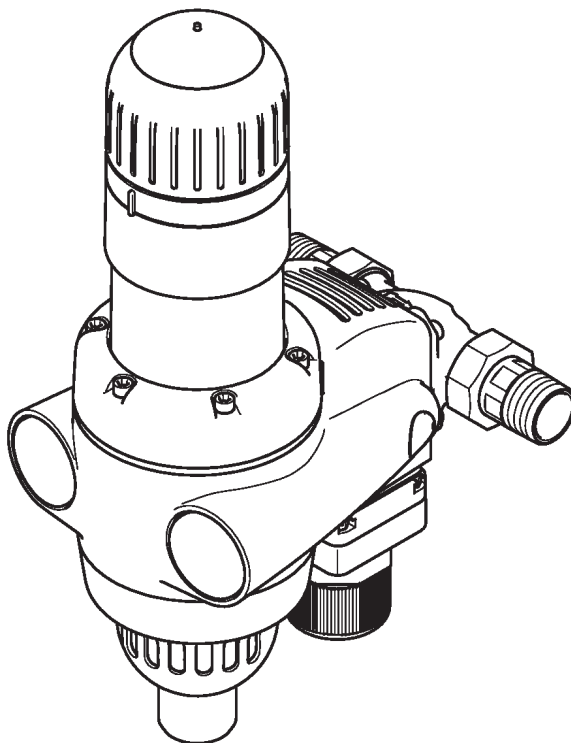

Read before use and store!

CE



judo®

Queries, orders, customer service

JUDO Wasseraufbereitung GmbH
Postfach 380
D-71351 Winnenden

Email: info@judo.eu • judo.eu

Office address:

JUDO Wasseraufbereitung GmbH
Hohreuschstraße 39 - 41
D-71364 Winnenden

Dear customers,

Thank you for the confidence you have shown in us by purchasing this product. You have purchased a state-of-the-art device. It has been carefully checked prior to delivery. Nevertheless, if difficulties occur, please contact the closest customer service (see chapter Customer service).

Trademarks:

Trademarks used in this document are the protected and registered trademarks of the owners.

© JUDO Wasseraufbereitung GmbH
D-71364 Winnenden

All rights reserved.

Reprinting, even in excerpt form, is only permitted with special approval.

These installation and operating instructions are intended for both installers, who are in charge of installing, maintaining or repairing the device, and for the operators of the device.

Contents	10	Customer service.....	24
1 Safety.....	4		
1.1 Intended use.....	4		
1.2 Application limits.....	4		
1.3 Safety instructions.....	4		
1.4 Symbols used.....	6		
1.5 Units used.....	6		
2 Product information.....	6		
2.1 Scope of supply.....	6		
2.2 Function description.....	6		
2.3 Materials used.....	7		
2.4 Approval marks.....	8		
3 Installation.....	8		
3.1 Conditions.....	8		
3.2 Installation of the rotary flange fitting.....	9		
3.3 Installation of the device.....	9		
3.4 Draining of the backwash water.	10		
3.5 Commissioning.....	11		
4 Operation.....	11		
4.1 Setting the downstream pressure.....	11		
4.2 Cleaning of the sieve insert (backwashing).....	11		
4.3 Conversions, changes.....	13		
4.4 Maintenance, repair, spare parts	13		
4.5 Temporary removal of the device.....	14		
5 Fault.....	15		
6 Servicing.....	16		
6.1 Cleaning.....	16		
6.2 Warranty and maintenance.....	16		
7 Technical data.....	17		
7.1 Installation dimensions.....	18		
7.2 Accessories.....	18		
7.3 Spare parts.....	19		
8 Disposal.....	22		
9 Maintenance log.....	23		

1 Safety

These operating instructions must always be available at the place of use of the device.

1.1 Intended use

The device is for the

- Filtration
- Pressure reduction
- Backflow prevention

of drinking water in domestic water piping and for residential, commercial and industrial use. It removes coarse and fine-grained particles from the drinking water, which are larger or equal to the mesh size of the filter, in order to prevent

- pipe damage caused by corrosion
- malfunctions of fittings or control and regulating devices caused by foreign bodies.

The device can be installed in all commercially available drinking water pipes. Both installation and use of the device are subject to the applicable national regulations.

i Particles that are smaller than the mesh size of the filter supplied and materials causing cloudiness cannot be filtered out of the water.

1.2 Application limits

1.2.1 Water quality

The water to be filtered must comply with the European Drinking Water Directive (98/83/EC). Before using the device with water that does not comply with this Directive, it is essential to consult the manufacturer.

1.2.2 Water pressure



CAUTION

The water pressure must not exceed 16 bar input pressure. The device must not be installed if the mains pressure is above 16 bar (even for a short time)!

Nominal pressure	PN 16
Operating pressure	1.5 bar - 16 bar
Downstream pressure	1.5 bar - 6 bar Factory setting: 4 bar

The water pressure must not fall below 1.5 bar as otherwise backwashing can be impaired!



Starting at an operating pressure of 10 bar, increased wear can be expected!

1.2.3 Water and ambient temperature

The filter is suitable for use in cold drinking water up to a maximum water and ambient temperature of 30 °C.

1.3 Safety instructions

1.3.1 Electrical danger



Risk of electric shock

No electrical wiring or equipment that is not splash-proof may run or be stored below the device. Electrical devices/ equipment located in the vicinity of the device must be splash-proof or comply with the legal regulations for wet rooms.

1.3.2 Warning of property damage



WARNING

Risk of water damage or damage to property

The device may only be installed by qualified technical personnel.

The installation room must be dry and free from frost.

The ambient temperature must not exceed 30 °C! In higher temperatures or direct sunlight, material damage may occur up to and including breakage of device parts.

An adequately sized wastewater connection (e.g. floor drain) in compliance with DIN 1986 must be provided.

In order to ensure safe drinking water hygiene, a free discharge of the wastewater acc. to DIN EN 1717 must be ensured.

The pipe must be able to safely support the device (weight: see chapter 7). If necessary, the pipes must be provided with additional fastenings or support.

If no bypass valve is installed, a shut-off valve must be installed upstream and downstream of the unit in order to interrupt the water supply during installation, maintenance, repair or malfunction of the device.

Install the device in a vertical position ($\pm 5^\circ$); the connection for waste water from backwashing must be directed downwards. Otherwise, water may escape and cause water damage.

For the installation of the device in domestic water piping, only use the supplied built-in rotary flange (see chapter 3.2).

The flange surface of the rotary flange fitting must be upright!

The rotary flange fitting must be fitted so that it is free from mechanical stress or strain. Otherwise mechanical damage to the pipe or the rotary flange fitting up to and including breaks can result.

For proper sealing the profile of the profile flange seal must point towards the rotary flange fitting (see Figure 2).

Only operate the device in a technically faultless condition:

- Check for damage prior to installation.
- Immediately have any malfunctions in operation rectified by qualified technical personnel.

Persons who, due to their physical, sensory or mental abilities or their inexperience or lack of knowledge, are unable to operate the device safely may not operate it without supervision or instruction from a responsible person.

Regular backwashing of the device is required to ensure safe drinking water hygiene (see chapter 4.2.1).

Before carrying out a backwash, ensure that the wastewater connection is functional.

At the end of the backwashing process, turn the handwheel until it engages so that no more backwash water escapes. Otherwise, water may constantly escape and cause water damage.

Do not use household cleaning agents to clean the outside of the device, but only use clear water to avoid embrittlement of the plastic.

The device may only be repaired by qualified technical personnel.

Only use original spare parts for repairs.

Before performing work on the device that goes beyond pure operational use, the device must be depressurised! If this is ignored, the result may be uncon-

trolled escape of water resulting in water damage to the building/home.





If the device is removed due to an interruption of operation:

- Protect the flange surfaces against damage to ensure proper sealing.
- Protect the device from dirt so as not to impair drinking water hygiene.
- Store the device in a frost-free place to prevent damage caused by freezing water and leakage.

Unauthorised conversions and changes are forbidden for safety reasons. These can impair the functioning of the device, leading to leaks and, in the worse case scenario, to bursting of the device.

1.4 Symbols used

The safety instructions contained in these operating instructions are labelled with the following symbols:

	Indication of existing dangers
	Warning of electric voltage
	Torques specified by the manufacturer
	User tips and other information

Instructions attached directly to the device, e.g.:

- Direction of flow (arrow)
- Type label
- Cleaning information

must be observed and maintained in legible condition.

1.5 Units used

Unit	Conversion
bar	1 bar = 10 ⁵ Pa = 0.1 N/mm ²
¾"	DN 20
1"	DN 25
1¼"	DN 32

2 Product information

2.1 Scope of supply

- Domestic water station, pre-assembled
- Built-in rotary flange
- 2 batteries for the electronic backwash reminder (size AAA)
- Installation and operating instructions

2.2 Function description

Unfiltered water flows into the device through the rotary flange. A coarse filter prevents large dirt particles from reaching the fine filter. The water flows from the outside to the inside through a cylindrical sieve insert. Dirt particles remain on the sieve fabric of the sieve insert. The adhering residues are visible from outside through the transparent filter bowl.

The filtered water continues to flow into the pressure reducer. The set downstream pressure can be read at the downstream pressure gauge.

Subsequently the filtered water exits the device again via the rotary flange fitting.

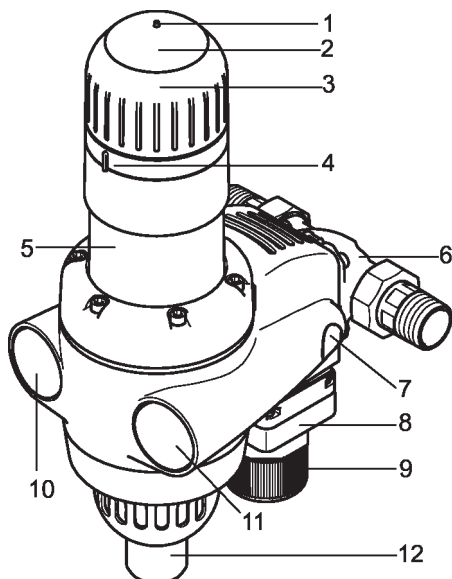

Fig. 1: Functional description

- 1 Reset button for beep as reminder that backwashing is due
- 2 Handwheel cover over battery compartment
- 3 Handwheel for backwashing
- 4 Adjusting ring for marking the next backwash date
- 5 Transparent filter bowl
- 6 Rotary flange fitting
- 7 Screw cover (check screw for backflow preventer on the side of the upstream pressure gauge)
- 8 Pressure reducer
- 9 Handwheel of the pressure reducer
- 10 Inlet pressure gauge
- 11 Outlet pressure gauge
- 12 Outlet backwash water

2.3 Materials used

The materials used are resistant to the physical, chemical and corrosive loads expected to be encountered in drinking water. They meet the requirements specified in the following standards:

- DIN EN 13443-1
- DIN 19628
- DIN 50930-6
- DIN EN 1567

All materials of components in contact with drinking water are hygienically and physiologically harmless and fulfill the requirements and directives of the Umweltbundesamt (UBA). Plastics fulfill the requirements of DIN EN 16421.

2.4 Approval marks



The device complies with the technical regulations for drinking water installation according to DIN EN 806ff. and the national supplement DIN 1988ff. as well as DIN EN 1717.

It has been tested and certified by the DVGW (Deutsche Vereinigung des Gas- und Wasserfaches e. V. - Technisch-wissenschaftlicher Verein) in accordance with the requirements

- of the DIN EN 13959 for backflow preventers
- of the DIN EN 1567 (pressure range PN 16) for pressure reducers
- of the DIN EN 13443-1 and DIN 19628 for mechanically active filters.

The device bears the DIN-DVGW mark as proof of certification.



Only devices with a standard sieve mesh width of 0.1 mm carry the DIN DVGW test mark. Devices with the available special mesh widths 0.03 mm, 0.32 mm and 0.5 mm are not part of the test according to DIN EN 13443-1 and DIN 19628 and are therefore not permitted to wear the approval mark.

3 Installation



CAUTION

The device may only be installed by qualified technical personnel.

Installation of the device upstream of the domestic water meter is forbidden.

3.1 Conditions



CAUTION

Risk of property damage or water damage!

The pipe must be able to safely support the device (weight: see chapter 7). If necessary, the pipes must be provided with additional fastenings or support.

To ensure convenient operation and maintenance of the device, always adhere to the specified clearances in chapter 3.4.1).

3.1.1 Requirements for the place of installation



CAUTION

The installation room must be dry and free from frost.

The ambient temperature must not exceed 30 °C! In higher temperatures or direct sunlight, material damage may occur up to and including breakage of device parts.

An adequately sized waste water connection (e.g. floor drain) in compliance with DIN 1986 must be provided.

3.2 Installation of the rotary flange fitting



CAUTION

The flange surface of the rotary flange fitting must be upright!

The rotary flange fitting must be fitted so that it is free from mechanical stress or strain. Otherwise mechanical damage to the pipe or the rotary flange fitting up to and including breaks can result.

The built-in rotary flange serves as a connecting element between the domestic water installation and the device. It is suitable both for horizontal and vertical pipes.

Attention: Install the built-in rotary flange in the flow direction! This is indicated by an arrow integral with the casting.



If the installation is twisted, a functioning of the device is not possible.

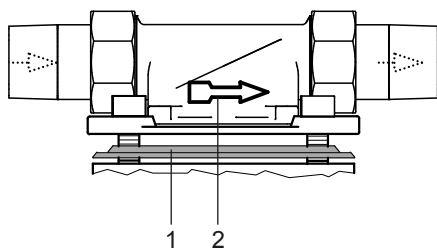

Fig. 2: Rotary flange fitting

- 1 Profile flange seal
- 2 Flow direction arrow

3.3 Installation of the device



CAUTION

If no bypass valve is installed, a shut-off valve must be installed upstream and downstream of the unit in order to interrupt the water supply during installation, maintenance, repair or malfunction of the device.

Install the device in a vertical position ($\pm 5^\circ$); the connection for waste water from backwashing must be directed downwards. Otherwise, water may escape and cause water damage.

For the installation of the device in domestic water piping, only use the supplied built-in rotary flange (see chapter 3.2).

The flange surface of the rotary flange fitting must be upright!

For proper sealing the profile of the profile flange seal must point towards the rotary flange fitting (see Figure 2: Rotary flange fitting, page 9).

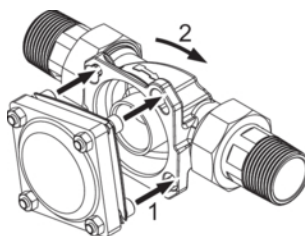

Fig. 3: Attach and engage appliance

- 1 Insert screws
- 2 Turn clockwise to engage screws

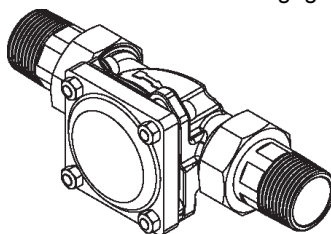

Fig. 4: Connection of appliance engaged

Do not undo the screws of the device!

- 1. Insert the heads of the four flange screws through the bayonet holes on the rotary flange fitting (see Figure 3).

2. Turn the device in clockwise direction up to the stop (see Figure 3 and Figure 4).
3. Tighten the four flange screws.

Nm Select the tightening torque (approx. 4 Nm) so that the seal is effective and the device is not damaged or strained!

3.4 Draining of the backwash water



CAUTION

An adequately sized waste water connection (e.g. floor drain) in compliance with DIN 1986 must be provided.

In order to ensure safe drinking water hygiene, a free discharge of the waste water acc. to DIN EN 1717 must be ensured.

The drain must be large enough so that all of the wastewater can be drained simultaneously.

If a wastewater connection directly beneath the device is not possible, the backwash water can be drained away via a hose or a pipe that is connected from the backwashing water valve over a few meters to the closest wastewater connection. The dimensioning of this pipe must correspond to the backwashing water valve.

If a bucket is used to drain off the backwash water:

- **Attention:** If the mains pressure is high, water may spray out of the bucket. Protect objects near the bucket from water damage!
- Carry out the backwashing quickly and finish the backwashing process as soon as the bucket is half full. Otherwise the bucket could overflow.

3.4.1 Drainage options for the backwash water

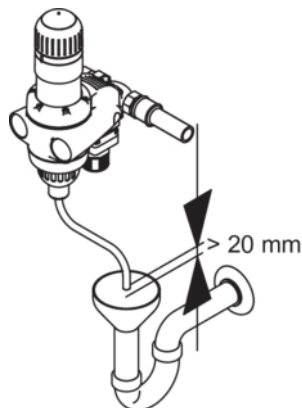
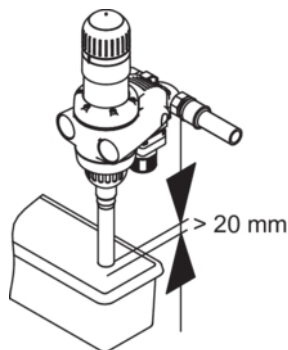
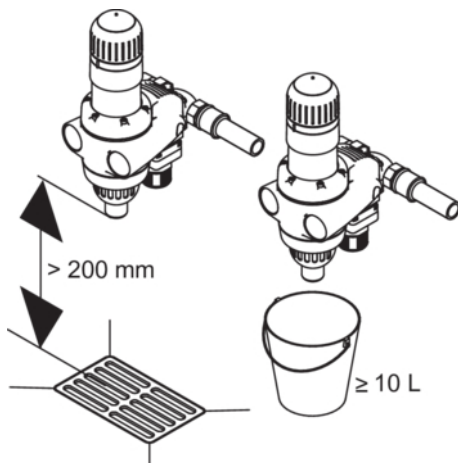

3.5 Commissioning

Prior to initial commissioning (or to commissioning after maintenance work) fill the installed device with water and vent:

1. Open the upstream shut-off valve to fill the device with water. The device is now under mains pressure.
 2. **Attention:** Carry out a backwashing immediately so that the trapped air can escape (see chapter 4.2.3)! This prevents damage to the installation by water hammer pressure surges.
- After backwashing, the device is vented and ready for operation.

3.5.1 Insert batteries

The backwash reminder alarm requires two 1,5 V Micro batteries.

How to insert the supplied batteries:

1. Lift the handwheel lid.
2. Insert the two batteries into the battery compartment.
3. Replace the handwheel lid.
4. Test the functionality of the batteries by pressing the Reset-button:
 - clearly audible beep: batteries are powerful.
 - no beep or only weakly audible: capacity of the batteries exhausted or insufficient.

4 Operation

4.1 Setting the downstream pressure

To compensate for pressure fluctuations and to protect the downstream installation, the downstream pressure can be regulated via the pressure reducer. The factory pre-set downstream pressure of 4 bar can be changed to a value between 1.5 bar and 6 bar depending on the upstream pressure:

1. Undo the countersunk screw on the handwheel of the pressure reducer.
2. Turn the handwheel clockwise (= pressure increase), or turn counter-clockwise (= pressure reduction).
3. Open a drawing point behind the device for a short time. This results in a pressure relief and the set downstream pressure can be read off from the downstream pressure gauge.
4. When the desired downstream pressure has been reached, retighten the countersunk screw on the pressure reducer handwheel to prevent automatic adjustment of the downstream pressure.

4.2 Cleaning of the sieve insert (backwashing)

A regular cleaning process is necessary to remove the residues from the sieve fabric of the device. This process is called **backwashing**.

Suction pipes are provided for backwashing, which rotate around the sieve fabric of the fine filter. The backwashing valve opens on the bottom side of the device. By reversing the water flow from inside to outside, deposits on the sieve fabric are carried away and rinsed out with the backwash water. The suction pipes also clean the inside of the transparent filter bowl with wiper lips during their movement.

The degree of contamination and cleaning process can be observed from the outside.

i The device is backwashed with filtered water. The filtered water supply of the domestic installation remains intact during the backwashing process. No dirty water can reach the pure water side during the backwashing.

4.2.1 Backwashing interval

If cleaning is not performed soon enough, the result may be damage to the sieve insert. Large quantities of filtered particles can deform the sieve fabric and in extreme case lead to tearing of the sieve fabric. In addition, larger deposit quantities can impair the backwashing function mechanically.

According to DIN EN 13443-1 backwashing the device is required at the latest every six months.

The manufacturer recommends a backwashing:

- at least every 2 months
- if the water pressure drops
- if the filter is visibly dirty

Experience has shown that new installations in the early stages of installation lead to increased dirt deposits. In this case, a more frequent backwashing is necessary.

4.2.2 Due date of backwashing

Every two months, a beep reminds you that the backwashing is due.

To switch off the beep, press the reset button on the handwheel cover.

→ By pressing the button, the time interval of 2 months is restarted.

The signal is just an additional reminder of the necessary backwashing. Independent from this signal, the backwashing interval indicated in chapter 4.2.1 must be observed.

Check backwash reminder alarm

Press the reset button for at least 3 seconds:

- **Beep:** the backwash reminder alarm works. The batteries still have enough capacity.
- **No beep:** replace the batteries by new leak-proof batteries.

This battery test has no influence on the backwashing interval.

Replace batteries of the backwash reminder alarm

1. Remove the handwheel cover.
2. Replace the batteries in the battery compartment by new ones of the same type (AAA or LR03).
3. Refit the handwheel cover.
4. Press the reset button on the handwheel cover for at least 3 seconds. The time interval of two months is restarted.

Attention: do not dispose of used batteries with the household waste, but in accordance with the local waste disposal regulations.

4.2.3 Backwashing



WARNING

Persons who, due to their physical, sensory or mental abilities or their inexperience or lack of knowledge, are unable to operate the device safely may not operate it without supervision or instruction from a responsible person.

Before carrying out a backwash, ensure that the wastewater connection is functional.

At the end of the backwashing process, turn the handwheel until it engages so that no more backwash water escapes. Otherwise, water may constantly escape and cause water damage.

1. Turn handwheel counter-clockwise up to stop. **Backwashing water escapes.**
 2. Turn handwheel clockwise up to stop. Ensure that no water escapes.
- The backwashing process is completed (see chapter 4.2).

4.3 Conversions, changes



WARNING

Unauthorised conversions and changes are forbidden for safety reasons. These can impair the functioning of the device, leading to leaks and, in the worse case scenario, to bursting of the device.

4.4 Maintenance, repair, spare parts



WARNING

The device may only be repaired by qualified technical personnel.

Only use original spare parts for repairs.

Before performing work on the device that goes beyond pure operational use, the device must be depressurised! If this is ignored, the result may be uncontrolled egress of water resulting in water damage to the building/home.

4.4.1 Checking the backflow preventer



WARNING

A defective backflow preventer must be replaced immediately.

The backflow preventer may only be replaced by trained technical personnel.

The testing screw at the inlet pressure gauge is used to check the function of the backflow preventer.

1. Close the stopcock or shut-off valve upstream of the device.
2. Remove the cover of the testing screw at the **inlet pressure gauge (water inlet)**.
3. Unscrew the testing screw with an allen key.
After a few seconds, no more water may escape from the pressure gauge connection.
4. Screw in the testing screw again.
Attention: set and screw in the screw straight so as not to damage the plastic thread.
5. Reassemble the cover of the testing screw.
6. Open the stopcock or shut-off valve upstream of the domestic water station again.

4.5 Temporary removal of the device



WARNING

If the device is removed due to an interruption of operation:

- **Protect the flange surfaces against damage to ensure proper sealing.**
- **Protect the device from dirt so as not to impair drinking water hygiene.**
- **Store the device in a frost-free place to prevent damage caused by freezing water and leakage.**

When recommissioning the device, proceed as with a new installation.

5 Fault

Fault	Possible cause	Remedy
Backwash water continues running.	Backwash valve is not fully closed.	Repeat backwashing and then turn the handwheel fully home to the stop.
	Dirt in backwash valve.	
Water flow decreases.	Sieve clogged.	Perform backwashing.
There are leaks in the filter bowl.	Damaged seals.	Inform the installer or the closest customer service point.
Filter bowl becomes clouded.	Filter bowl was exposed to high temperatures or solvents.	<ul style="list-style-type: none"> Inform the installer or the closest customer service point. If water escapes, close shut-off valves. Have the filter bowl replaced immediately.
Hairline cracks on the filter bowl.		
The downstream pressure increases slowly at zero flow.	Inadmissible pressure increase due to process water heating.	Check the safety relief valve of the warm water boiler. Inform the installer or the closest customer service point.
	Wear of the pressure reducer cartridge.	

Table 1: Troubleshooting

6 Servicing

6.1 Cleaning



CAUTION

Do not use household cleaning agents to clean the outside of the device, but only use clear water to avoid embrittlement of the plastic.

6.2 Warranty and maintenance

Prerequisite for obtaining the statutory warranty claim is regular backwashing (see chapter 4.2). The DIN EN 13443-1 prescribes that the backwashing must take place every six months. JUDO however recommends to comply with the information in chapter 4.2.1 Backwashing interval.

Furthermore, the set outlet pressure must be checked annually on the outlet pressure gauge, both at zero flow and at peak flow (large withdrawal). If necessary, the setting of the outlet pressure must be readjusted.

To ensure the process operates successfully as long as possible, regular inspection and routine servicing of the device are essential. Where home automation is concerned, this is governed by DIN EN 806-5.

We recommend the conclusion of a maintenance contract, which is the best way to ensure a good operating function, even beyond the warranty period. The skilled tradesmen or the factory customer service are suitable partners for regular maintenance work and the supply of consumables and wear materials as well as for possible repairs.

7 Technical data

Domestic water station

JUDO PROMI-PLUS ¾" - 1¼"

JPM+ ¾" - 1¼"

The water to be filtered must comply with the European Drinking Water Directive.

Information about:	JPM+ ¾"	JPM+ 1"	JPM+ 1¼"
Pipe connection	¾"	1"	1¼"
Backwashing volume flow ¹⁾	0.3 L/s	0.3 L/s	0.3 L/s
Nominal pressure	PN 16	PN 16	PN 16
Operating pressure	1.5 - 16 bar	1.5 - 16 bar	1.5 - 16 bar
Rated flow acc. to DIN EN 1567	2.3 m³/h	3.6 m³/h	5.8 m³/h
Settable downstream pressure	1.5 bar - 6 bar	1.5 bar - 6 bar	1.5 bar - 6 bar
Factory setting of downstream pressure	4 bar	4 bar	4 bar
Mesh size sieve insert ²⁾	100 µm 0.1 mm	100 µm 0.1 mm	100 µm 0.1 mm
Water temperature and ambient temperature	max. 30 °C	max. 30 °C	max. 30 °C
Threaded connection according to	DIN EN 10226-1		
Weight	4.2 kg	4.3 kg	4.7 kg
Order no.	8170200	8170201	8170202

1) Applies to a fully opened backwashing valve and 2 - 3 bar mains pressure.

2) Standard sieve mesh size

Available special sieve mesh sizes (30 µm / 0.03 mm, 320 µm / 0.32 mm and 500 µm / 0.5 mm) for the industrial use are not part of the testing acc. to DIN EN 13443-1 and DIN 19628 and therefore can not bear the DIN-DVGW mark.

7.1 Installation dimensions

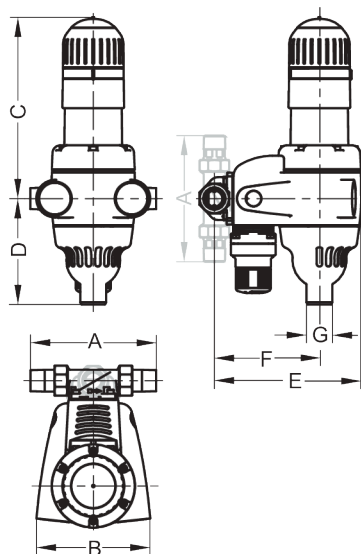

Fig. 5: Installation dimensions

	JPM+ ¾"	JPM+ 1"	JPM+ 1¼"
A	180	195	230
B	176	176	176
C	280	280	280
D	165	165	165
E	227	227	232
F	162	162	167
G	40	40	40

Table 2: Dimensions without unit in mm

- A Installation length
- B Width of the device
- C Height above the pipe middle
- D Height below the pipe middle
- E Installation depth up to the pipe middle
- F Waste water connection up to the pipe middle
- G Waste water nominal diameter

7.2 Accessories

- JUDO Expansion QUICKSET JQR (order no. 8250041) for series connection of two devices, e.g. filter and water treatment plant
- JUDO Bypass valve JQX (order no. 8735210)
- JUDO ECO-SAFE leak protection (order no. 8140010)

7.3 Spare parts

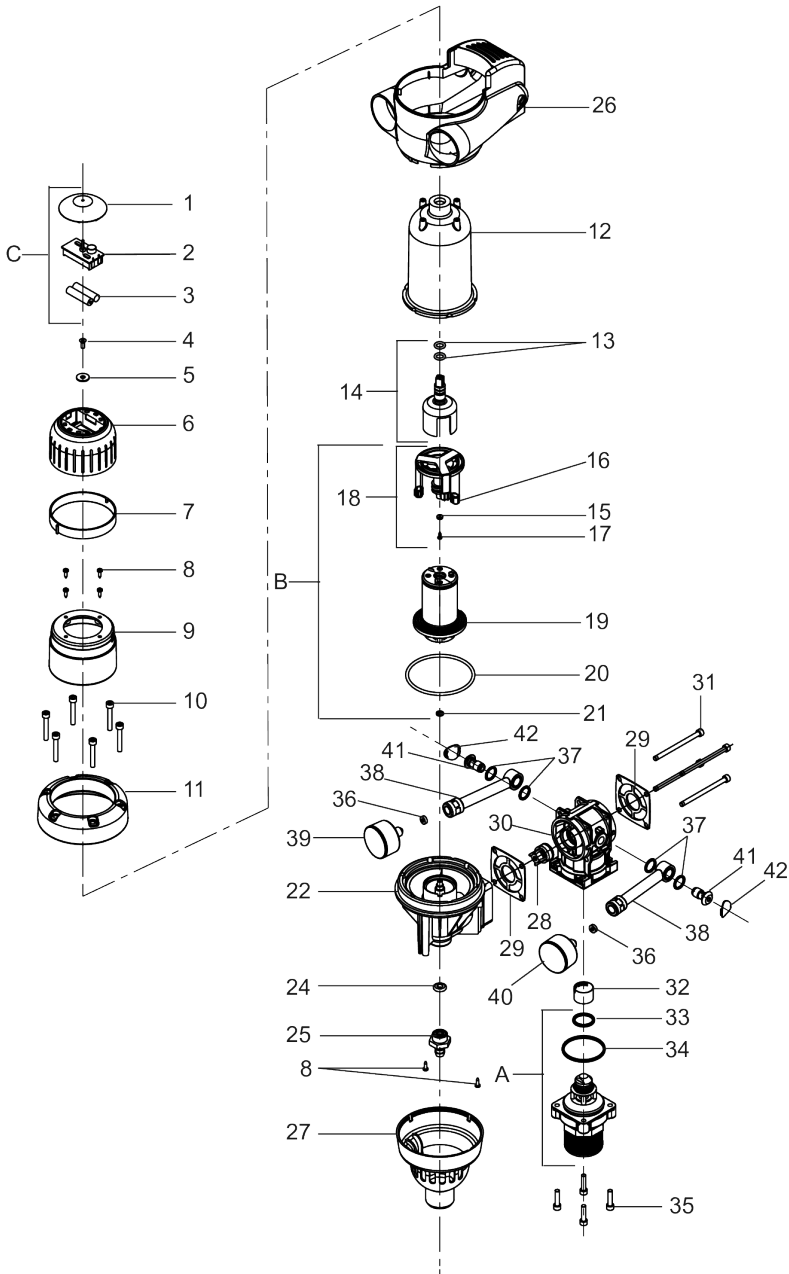

Item	Designation	Pcs	Order No.	AU ¹⁾ / Pcs
A	Wear parts set "Pressure reducer cartridge" ****	1	2150026	105
--	Wear parts set "Gaskets" **** (consisting of pos. 13, 15, 16, 17, 20, 21, 24, 29, 36, 37)	1	2010335	42
B	Wear parts set "Sieve 0.1 mm, suction pipe and gaskets" *** (consisting of pos. 18, 19, 20, 21)	1	2020819	159
B	Wear parts set "Sieve 0.1 mm, suction pipe and gaskets" *** (consisting of pos. 18, 19, 20, 21) - not for DE -	1	2021359	166
C	Spare parts set "Backwash reminder alarm" (consisting of pos. 1, 2, 3)	1	2010495	49
1	Handwheel lid	1		
2	Backwash reminder alarm	1		
3	Battery 1,5 V Typ AAA (set with 2 pcs)	1	2060347	8
4	Countersunk screw M5×12	1		
5	Disc A 6,4	1		
6	Memo handwheel	1		
7	Setting ring	1		
8	Sheet metal screw 3,5×13	6		
9	Top of housing printed ¾"	1		
9	Top of housing, printed 1"	1		
9	Top of housing, printed 1¼"	1		
10	Cylinder screw M6×40	6		
11	Flange ring	1		
12	Filter bowl	1	2010424	149
13	O-ring 10×3	2		
14	Driver	1	2010146	53
15	Suction pipe gasket	1		
16	Nozzle	3		
17	Sheet metal screw 2,9×9,5	1		
18	Suction pipe, complete	1		
19	Sieve insert	1		
20	O-ring 90×4	1		

Table 3: List of spare parts JPM+ ¾" - 1¼"

Item	Designation	Pcs	Order No.	AU ¹⁾ / Pcs
21	O-ring 6,5×2	1		
22	Filter bottom	1		
24	O-ring 6,5×6	1		
25	Hose connection piece	1		
26	Housing, printed	1		
27	Filter funnel	1		
28	Backflow preventer	1		
29	Profile flange gasket	2		
30	Housing	1		
31	Cylinder screw M6×88	4		
32	Noise sieve	1		
33	O-ring 25×3,5	1		
34	O-ring 52×3,5	1		
35	Cylinder screw M6×25, Set with 4 pcs	1	2060333	2
36	Pressure gauge seal	2		
37	O-ring 14,5×2,5	4		
38	Pressure gauge connection piece	2		
39	Pressure gauge 0 - 16 bar (inlet)	1	2170120	20
40	Pressure gauge 0 - 10 bar (outlet)	1	2170121	20
41	Hollow screw	2		
42	Screw cover	2		

Table 3: List of spare parts JPM+ ¾" - 1¼"

1) AU = Accounting unit (items without AU are only available in a set)

Replacement interval: *** = 3 years **** = 4 years

8 Disposal

Packaging waste is to be sent to the local recycling system.

To protect environment, old appliances and used batteries must not be disposed of with household waste. Instead, use the local collection and return points, which are committed to free and environmentally sound disposal.



9 Maintenance log

Product designation:

Domestic water station

Order number:

Serial number:

Date	Work activities performed	Company / signature

10 Customer service

- DE** **JUDO Wasseraufbereitung GmbH**
Postfach 380 • D-71351 Winnenden
Phone +49 (0)7195 / 692-0
E-mail: info@judo.eu • judo.eu
- AT** **JUDO Wasseraufbereitung GmbH • Niederlassung Österreich**
Josef-Sandhofer-Straße 15 • A-2000 Stockerau
Phone +43 (0)22 66 / 6 40 78 • Fax +43 (0)22 66 / 6 40 79
E-mail: info@judo-online.at • judo-online.at
- CH** **JUDO Wasseraufbereitung AG**
Industriestrasse 15 • CH-4410 Liestal
Phone +41 (0)61 906 40 50 • Fax +41 (0)61 906 40 59
E-mail: info@judo-online.ch • judo-online.ch
- BENELUX** **JUDO Wasseraufbereitung GmbH • Filiaal - Filiale Benelux**
Laarbeeklaan - Av. du Laerbeek, 72 A1 • B-1090 Brussel-Bruxelles
Phone +32 (0)24 60 12 88 • Fax +32 (0)24 61 18 85
E-mail: info.benelux@judo.eu • judo.eu
- FR** **JUDO France SARL**
76 Rue de la Plaine des Bouchers (Technosud) • F-67100 Strasbourg
Phone +33 (0)3 88 65 93 94 • Fax +33 (0)3 88 65 98 49
E-mail: info@judo.fr • judo.fr

Installed by / on:

All pictorial, dimensional and implementation information correspond to the date of going to press. We reserve the right to make changes due to technical progress and continuing development. Model and product claims cannot be lodged.